

NOTES:
 REACTOR MATERIAL: ALUMINUM

REVISION HISTORY			
REV	DESCRIPTION	DATE	APPROVED
2C	INITIAL RELEASE	11/5/2024	ENGINEERING

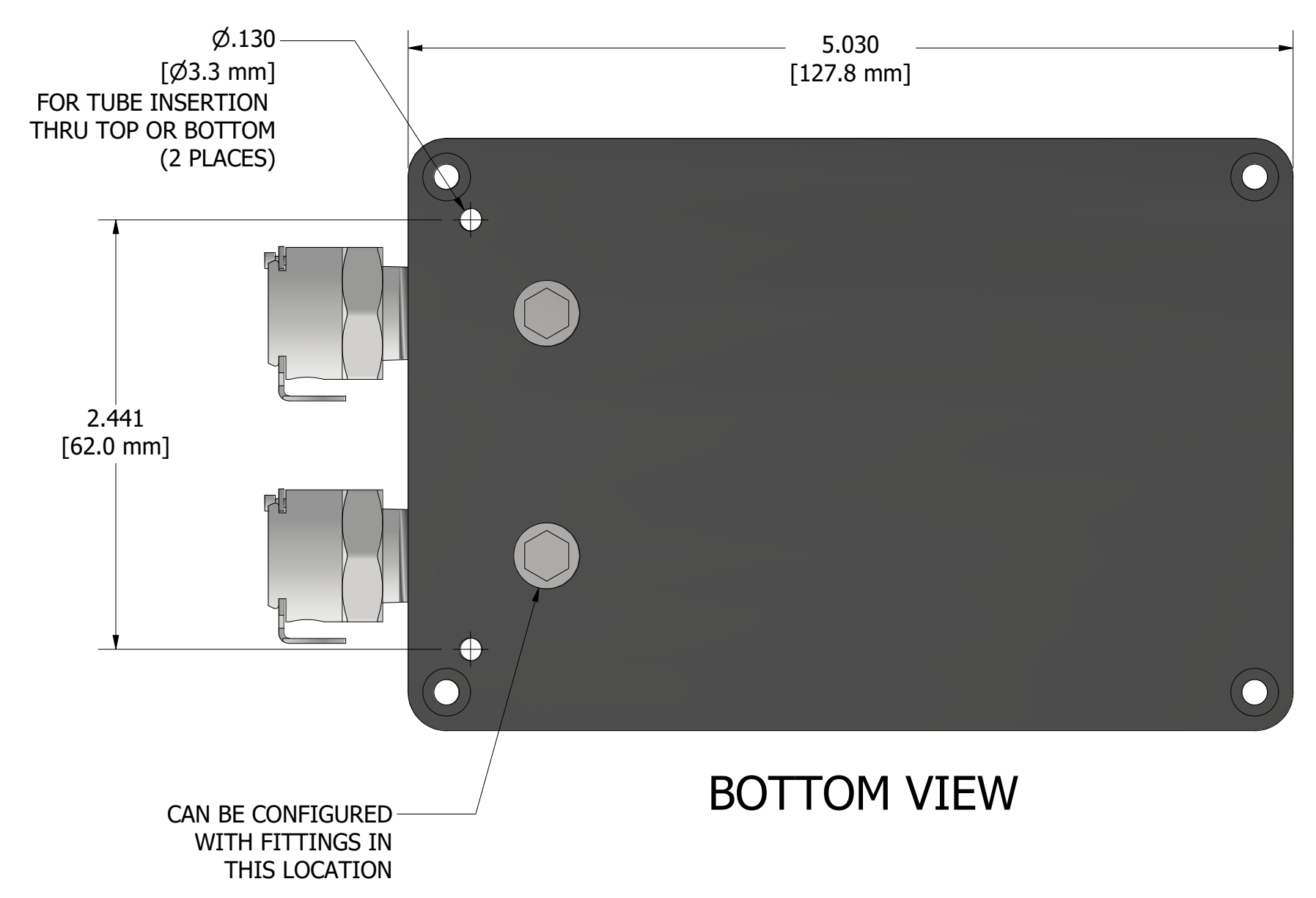
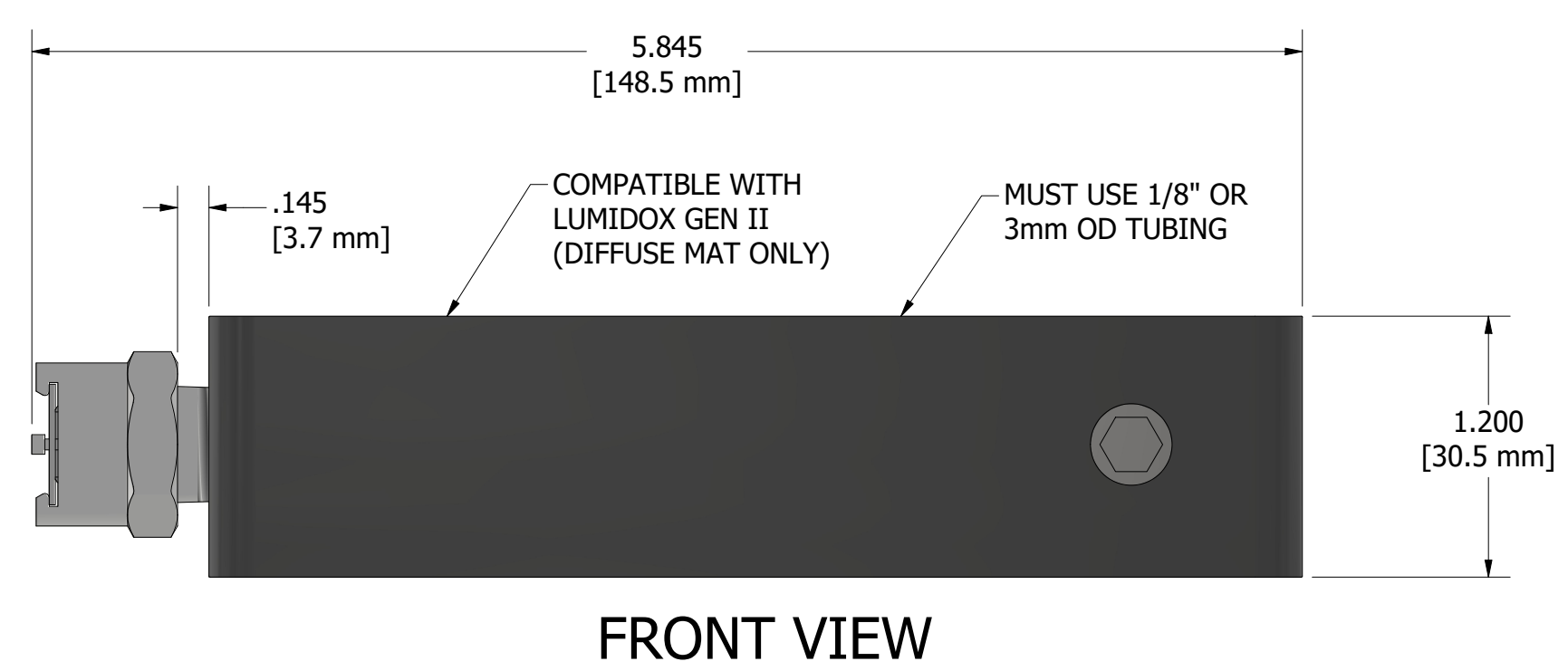
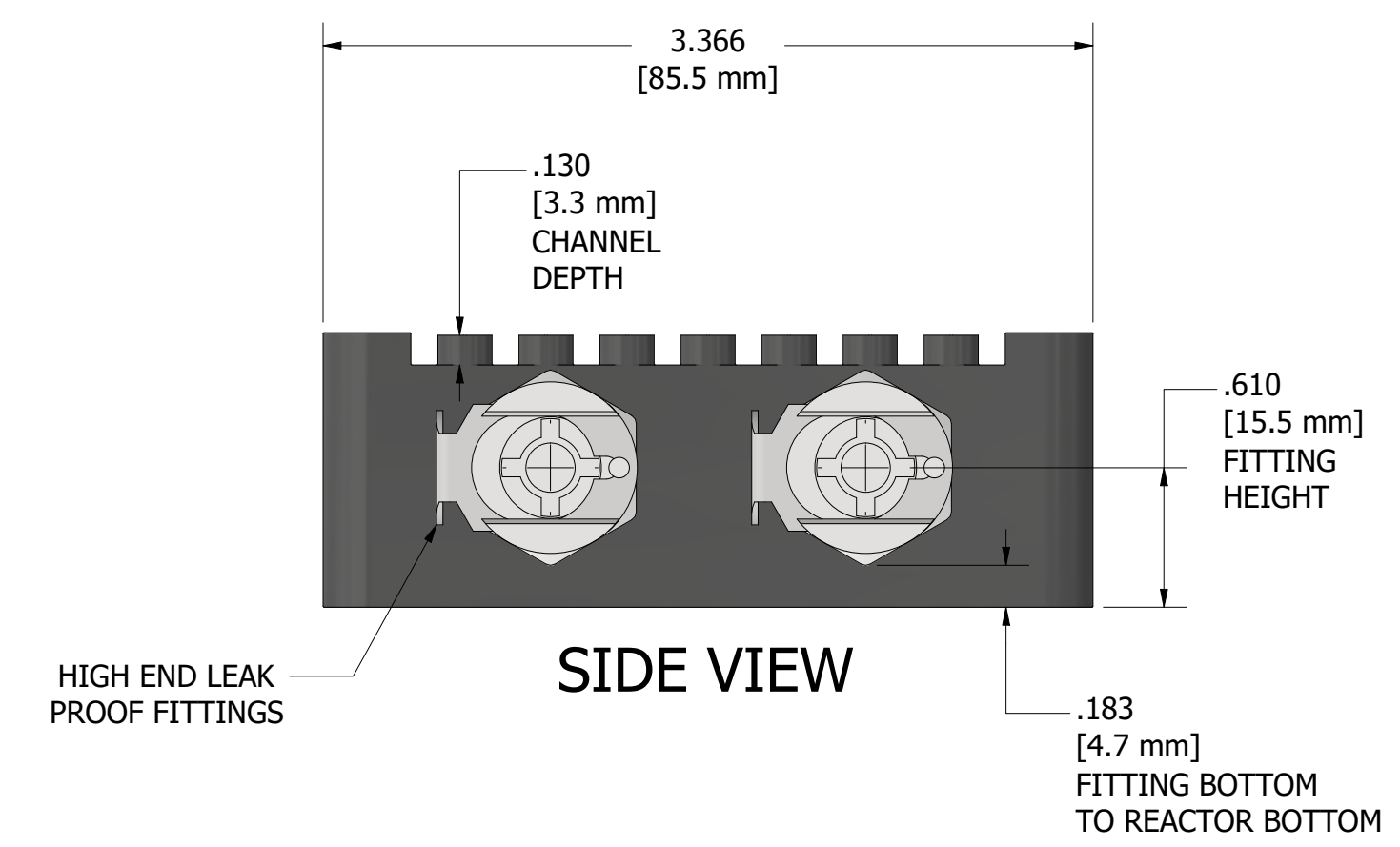
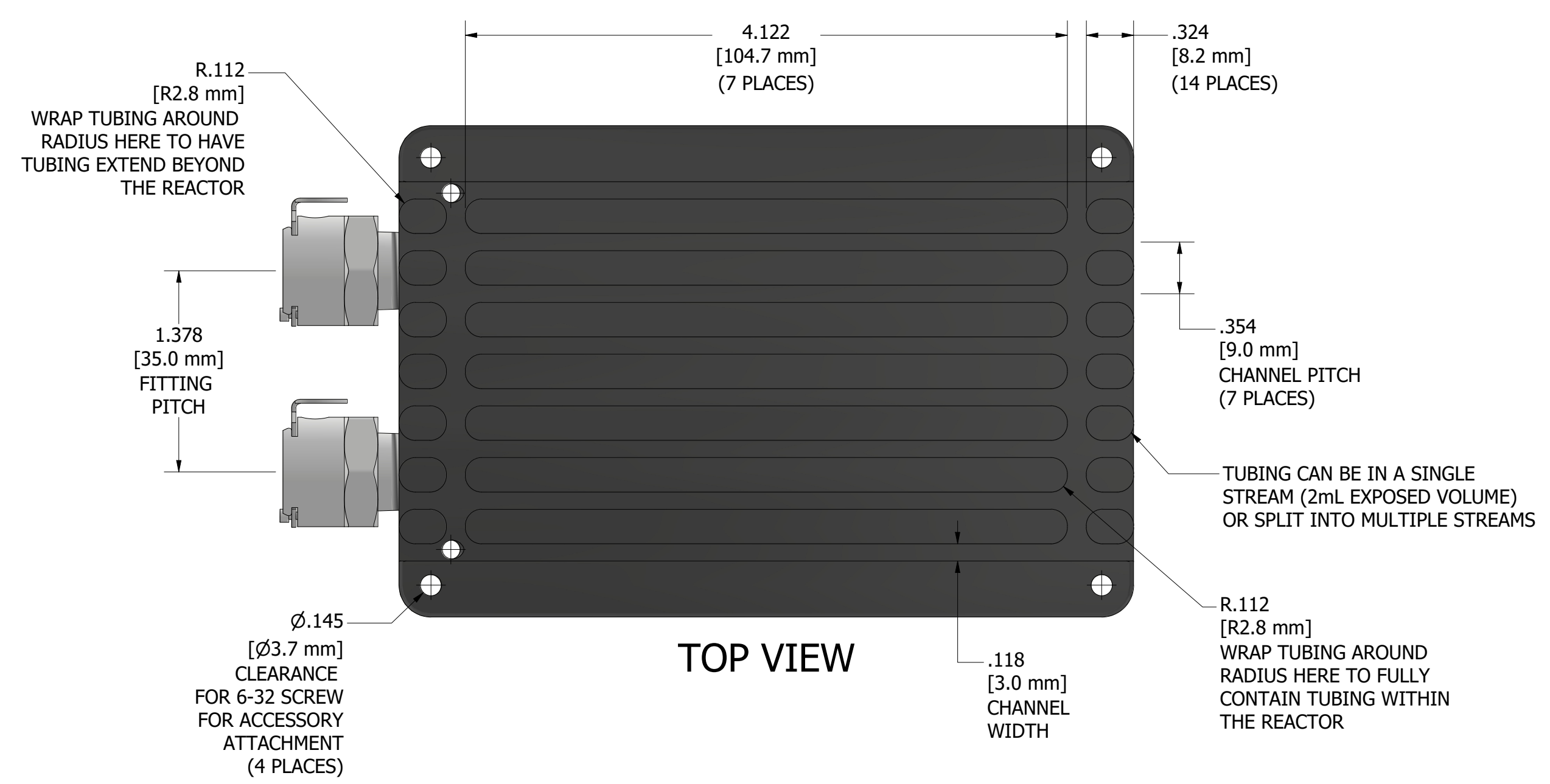
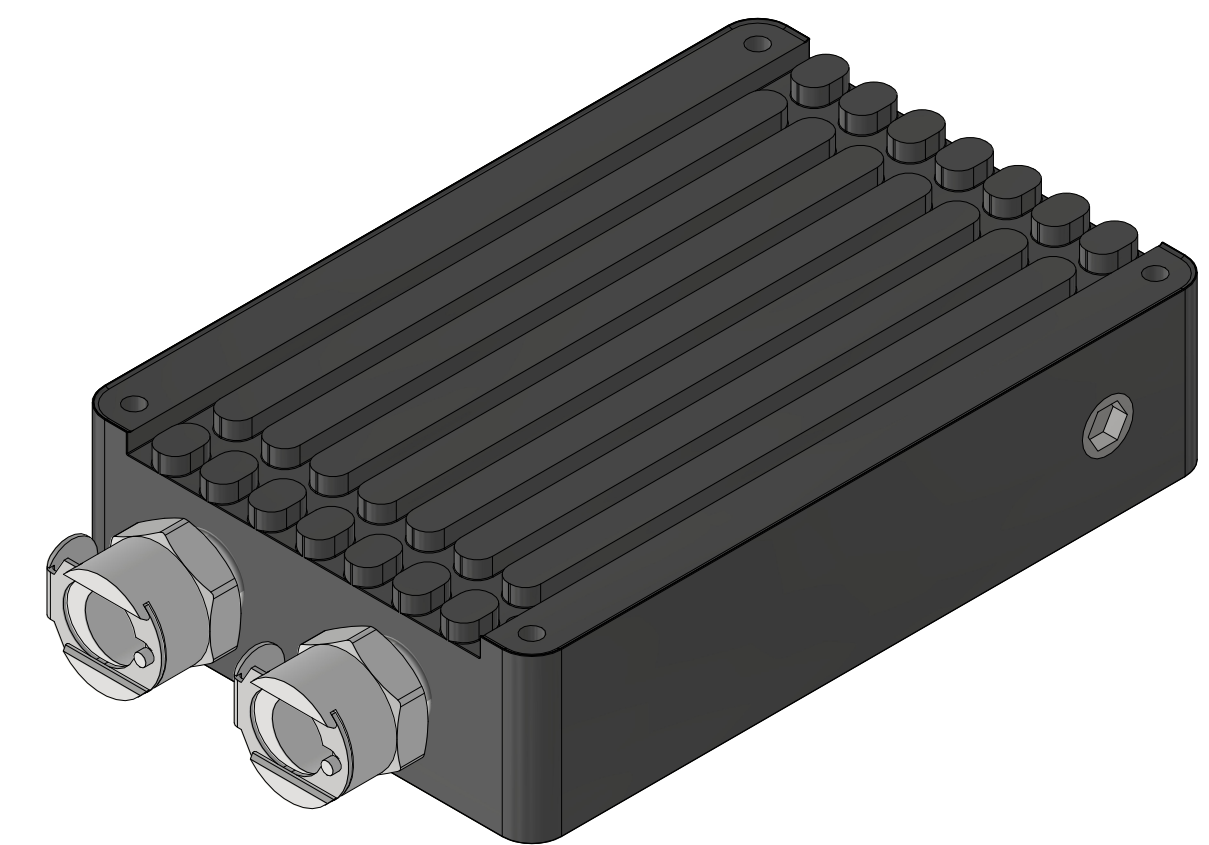

DRAWN SAS email engineering@analytical-sales.com	11/5/2024	ANALYTICAL SALES AND SERVICES, INC © 2024	
TITLE		266100_flow_reactor_rev2c_PUBLIC	
SIZE D		REV 2C	
SCALE	5 : 4	SHEET 1 of 1	

P